

Telemetry TT01

Telemetry TT01 is intended for amplifying and contactless transmission of signals from the strain gauges (thermocouples) mounted on the rotating machine parts to the stationary measuring unit or data acquisition system. It is suitable for measurements of various physical quantities such as strains, forces, torque, temperature, etc. TT01 is ideal to be applied to shafts, axles, connecting rods and the like when low-cost and effective solution to the measurement task is needed.

The principle of operating Telemetry TT01 is based on the conversion of the signal produced by the strain gauge (thermocouple) into the frequency-modulated impulses and on the transmission of them by means of capacitive coupling between transmitter and receiver from the rotated object on the fixed object.

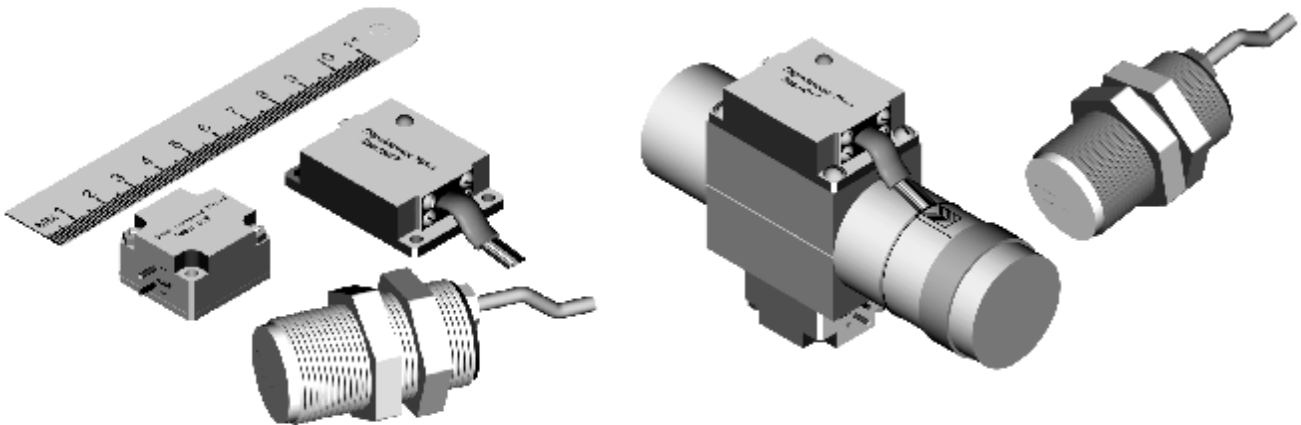

Dimensions, mm

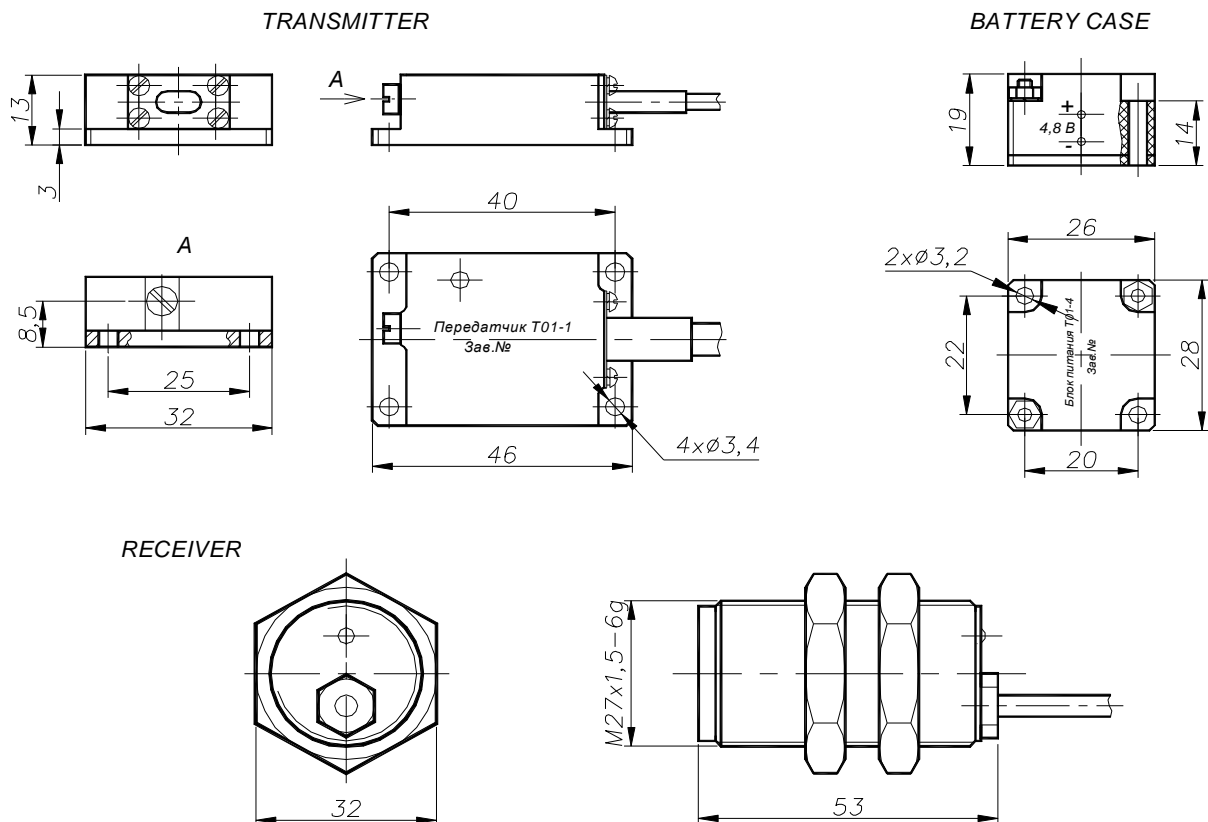

Technical Data

Type		TT01
Number of measuring channels		1
Permissible strain gauge full bridge resistance	Ω	100...1000 (thermocouple on request)
Nominal input signal, switchable in 3 steps	mV/V	$\pm 0.5, \pm 1.0, \pm 2.0$
Bridge excitation voltage	V	3.5...5.5
Bridge balance range	mV/V	± 2
Nominal output voltage of receiver at nominal input signal	V	3 ± 2.5 (0 ± 2.5 on request)
Characteristic tolerance	%	± 0.5
Temperature effect per 10K in the nominal temperature range on the zero point at the receiver output	%	<0.2
Linearity deviation	%	<0.1
Measurement frequency range (-3dB)	Hz	0...500 (0...5000 on request)
Operating voltage of transmitter	V	4.8 (3.5...5.5)
Operating current of transmitter (without bridge connected)	mA	<15
Operating voltage of receiver	V	10...32
Operating current of receiver	mA	<20
Degree of protection		IP52
Nominal temperature range	$^{\circ}\text{C}$	-40...+60
Permissible acceleration (transmitter and case battery)	m/s^2	35000
Weight of transmitter	g	40 ± 2
Weight of battery case T01.4 110 mAh	g	35 ± 2
Weight of receiver (without cable)	g	140 ± 5
Receiver cable length	m	10

Scope of delivery

Transmitter T01.1	1
Receiver T01.2 (with cable 10m)	1
Battery box T01.4 110 mAh	1
Operating manual	1

Accessories, to be ordered separately:

1. Rotating transformer TB01 or TB10
2. Battery case T01.3 280 mAh

TILKOM can produce telemetry systems in accordance with Customized specific requirements.
Modifications reserved.